



## » Sugar dissolving and mixing tank SO-Z

Whether it is about mixing, blending or stirring: because of its unlimited application possibilities, Speidel's SO-Z tank is indispensable for almost any enterprise.

Our customers appreciate the tank's perfect functioning and its outstanding price-performance ratio. The tank's PE-base allows easy and flexible transportation. The base can be easily accessed from underneath by forklift / pallet truck. At the same time the base serves as buffer / bumper.

This tank combines both our know-how in matters of stainless steel and our expertise in plastics. The tank's PE-base is home-made and is therefore ideally customised for the tank. It fits like a glove.

**For forklift and pallet truck transportation**



### APPLICATION RANGE (PRESSURELESS)

- › Blending
- › Stirring
- › Mixing
- › Storage

Ideal for  
› All kinds of beverages

**STANDARD EQUIPMENT FOR SUGAR DISSOLVING AND MIXING TANK SO-Z**

- › AISI 304 stainless steel, surface IIIId (2R), marbled outside
- › Open tank top with strengthening rim
- › Connecting neck for stirring device with external thread connection 37W 47 x 1/9"
- › Vaulted, stable tank bottom with integrally moulded forward down-slope for complete draining
- › Moulded connection neck with bottom outlet: in case of 820 mm  $\varnothing$  external thread NW 40 DIN 11851, from 1,000 mm  $\varnothing$  upwards external thread NW 50 DIN 11851
- › PE-transportation and storage base, accessible from underneath by forklift / pallet truck
- › Up to 530 litres capacity with PE-transportation and storage base, accessible from two sides by forklift / pallet truck
- › From 750 litres capacity onwards with PE-transportation and storage base, accessible from four sides by forklift / pallet truck

**DIMENSIONS OF SUGAR DISSOLVING AND MIXING TANK SO-Z**

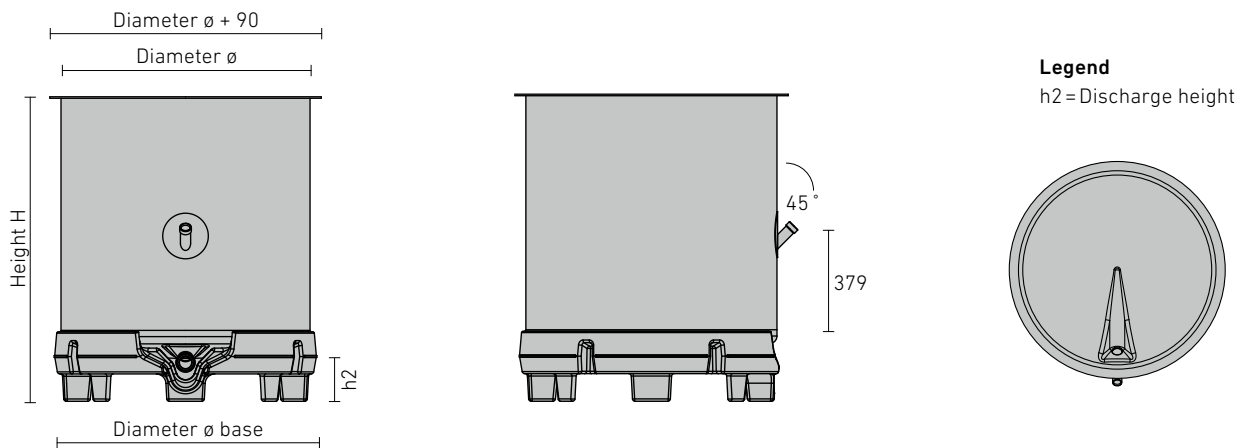

Capacity litres	ø Tank mm	ø Base mm	H mm	h2 mm	Discharge NW	Order No.
530	820	873	1,315	160	40	SO-Z-082- 0530
750	1,000	1,054	1,218	135	50	SO-Z-100- 0750
1,000	1,200	1,256	1,218	115	50	SO-Z-120- 1000

Stirring device traverse with flap lid and stirring device on request

