

Don't ruin the fruits of your labour  
with a bad tank



## » Distilling mash tank FD-B

For high quality distilleries the mash tank FD-B is a must-have. In order to turn fine fruits into fine liquor, the mash needs to be processed professionally. This is where Speidel comes into play, because good mash simply needs a good tank.

The tank's plastic base for transportation and storage guarantees the tank's easy and safe handling. Due to the base the tank is, of course, accessible from underneath by forklift / pallet truck.



### APPLICATION RANGE (PRESSURELESS)

- › Storage
- › Transportation
- › Maturation

- Ideal for
- › Fruit mash
  - › Wine
  - › Must
  - › Spirits

## STANDARD EQUIPMENT FOR DISTILLING MASH TANK FD-B

- › AISI 304 stainless steel, surface III d (2R), marbled outside
- › With lifting lugs
- › Vaulted, stable tank top with filler neck NW 400 mm
- › Up to tank- $\varnothing$  of 820 mm arranged in the centre of the tank top
- › From tank- $\varnothing$  of 1,000 mm upwards arranged up-front in tank top
- › Flap lid with outer clamp fastener, stainless steel vent neck AGG 1 1/2" (BSP) with sealing cap to hold fermentation lock and bung

**BOTTOM OUTLET**

- › Discharge neck NW 65 with outlet external thread G 2 1/2" (BSP)
- › PE-transportation and storage base, accessible by forklift / pallet truck

## DIMENSIONS OF DISTILLING MASH TANK FD-B

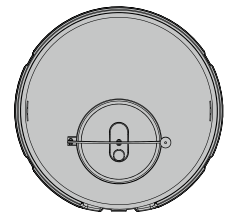
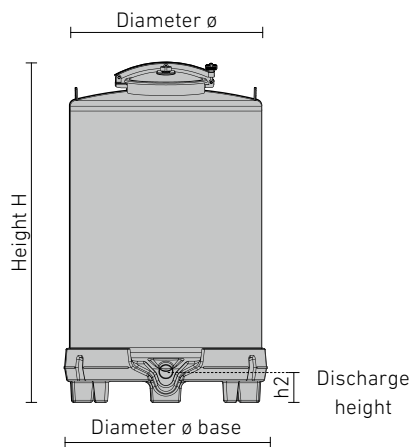

Capacity	$\varnothing$ Tank	$\varnothing$ Base	H	h2	Order No.
litres	mm	mm	mm	mm	
525	820	873	1,440	160	FD-B-082-0525
625	820	873	1,635	160	FD-B-082-0625
750	820	873	1,898	160	FD-B-082-0750
1,050	1,000	1,054	1,810	135	FD-B-100-1050
1,850	1,200	1,256	2,075	115	FD-B-120-1850

